

**Mini Crawler Crane**

# MC285C-2



**Slim Body Width : 750mm**  
**Lifting Capacity : 2.82t x 1.4m**  
**Programmable Moment Limiter**  
**Crane/Outrigger Interlock System**  
**Digital Feedback Remote Control**  
**4 Fall/2 Fall Hook Block**  
**Voice Warning System**  
**Data Logger**



**Moment Limiter**

**Available with**

**Searcher Hook**

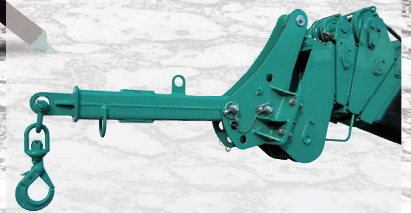

**Electric Motor**



**Auxiliary Winch**



# MAEDA Mini Crawler Crane MC285C-2

## Specifications

Model		MC285C-2
Crane capacity		2,821 × 1.4m
Max. working radius		8,205m × 0.15t
Max. lifting height (on the ground)		8.7m
Max. lifting height (underground)		-10.1m (4 falls)
Max. lifting height (underground) (optional auxiliary winch)		-100m (single fall)
Winch system	Hook speed	9.3m/min (4 layers, 4 falls)
	Hoist wire rope	IWRC 6 × Fi (29) 0/0, φ7 × 48.0m
Telescoping system	Type	Fully automatic 5-section pentagonal telescopic boom (3 to 5 section: Simultaneous telescoping)
	Boom length	2.535m ~ 8.575m
	Boom telescoping stroke / time	6.04m / 22sec
Boom hoist system	Hoist angle / time	0 to 80deg / 14.0sec
Swing system	swing angle / time	360 deg / 1.0rpm
Outrigger system	Type	1st stage with flexible stay damper, 2nd stage manual pullout, hydraulic cylinder direct acting type
	Max. extended width	(Lateral) 4,580 × (Front) 4,530 × (Rear) 3,810mm
Travel system	Type	Hydraulic motor driven, stepless speed changer
	Travel speed	0~2.2km/h
	Gradability	20deg
	Crawler ground length × width	975 × 200mm
	Ground pressure (MC285CRM-2)	48.7kpa [0.497kgf/cm <sup>2</sup> ]
	Ground pressure (MC285CGRM-2)	47.8kpa [0.487kgf/cm <sup>2</sup> ]
Engine (diesel)	Model	YANMAR 2TNV70-NMB
	Displacement	569cc [0.569L]
	Rated output	7.4kw [10.1ps] / 2,500rpm
	Starting method	Electric starting
	Fuel / Fuel tank capacity	Diesel / 12.0L
	Model	Briggs & Stratton 3564
Engine (petrol) (MC285CGRM-2)	Displacement	570cc [0.570L]
	Rated output	10.8kw [14.7PS] / 2,600rpm
	Starting method	Electric starting
	Fuel / Fuel tank capacity	Petrol / 8.0L
Motor (MC285CRME-2)	Motor model	W21 4P-5.5kw
	Motor type	Totally enclosed fan-cooled motor 5.5kw, 4P 380V
Remote control system	Starting system	Inverter system (30Hz-60Hz)
	Type	Cable remote controller
Safety device	Features	Micro speed mode, Digital feedback, Voice
	Overall length × width × height (MC285C(G)RM-2)	2,750mm × 750mm × 1,470mm
Optional equipment	Overall length × width × height (MC285CRME-2)	3,320mm × 750mm × 1,470mm
	Machine weight (MC285CRM-2)	1,960kg
	Machine weight (MC285CGRM-2)	1,900kg
Machine weight (MC285CRME-2)	2,120kg	
Safety device	Overwind protection, Angle indicator, Hydraulic safety valve, Wire rope latch, Level, Machine body inclination alarm, EMO switch, Moment limiter, Working status lamp, Date logger, Outrigger setting lamp, Crane & Outrigger interlock device	
Optional equipment	White rubber tracks, Single fall hook, 300kg/850kg searcher hook, 900kg auxiliary winch, Oil cooler kit (MC285CGRM-2)	

## Dimensions

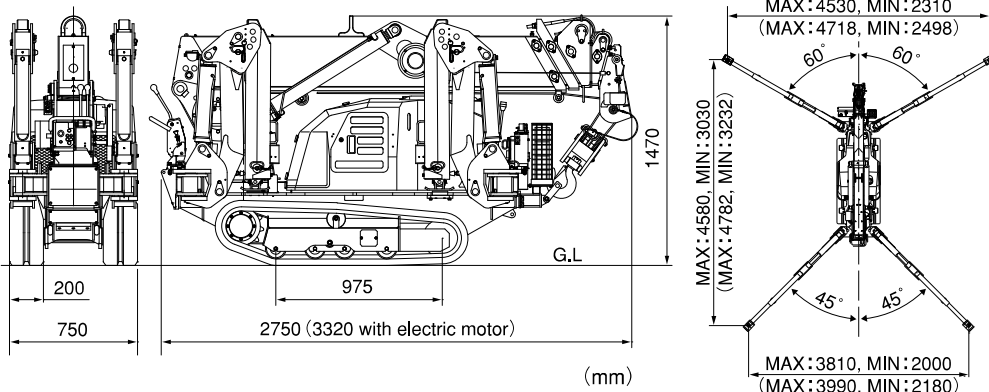

**Before use, please read the Operation Manual**

Due to improvements, the specifications are subject to change without notice.

## Rated Total Load Chart (4 falls)

Rated Total Load Chart with outrigger extended to maximum							
2.535m/4.075m Boom		5.575m Boom		7.075m Boom		8.575m Boom	
Working radius (m)	Rated total load (kg)	Working radius (m)	Rated total load (kg)	Working radius (m)	Rated total load (kg)	Working radius (m)	Rated total load (kg)
1.4 or less	2820	3.0 or less	1220	3.6 or less	820	4.0 or less	550
1.5	2520	3.5	970	4.0	740	4.5	400
2.0	1920	4.0	780	4.5	580	5.0	340
2.5	1570	4.5	630	5.0	480	5.5	300
3.0	1220	5.0	530	5.5	430	6.0	270
3.5	970	5.205	530	6.0	380	6.5	230
3.705	920			6.5	350	7.0	200
				6.705	330	7.5	180
						8.0	150
						8.205	150

Rated Total Load Chart with outrigger extended to other than maximum							
2.535m/4.075m Boom		5.575m Boom		7.075m Boom		8.575m Boom	
Working radius (m)	Rated total load (kg)	Working radius (m)	Rated total load (kg)	Working radius (m)	Rated total load (kg)	Working radius (m)	Rated total load (kg)
1.5 or less	1720	3.0 or less	510	3.6 or less	400	4.0 or less	330
2.0	1070	3.5	410	4.0	330	4.5	280
2.5	630	4.0	330	4.5	280	5.0	230
3.0	520	4.5	280	5.0	230	5.5	180
3.5	390	5.0	200	5.5	180	6.0	160
3.705	350	5.205	200	6.0	160	6.5	130
				6.5	130	7.0	100
				6.705	120	7.5	80
						8.0	70
						8.205	60

\* The Rated Total Load Chart is based on actual working radius including boom deflection.  
 \* The weight of hook block (standard 4 fall / 2 fall-30kg) must be included as part of the load shown in the Rated Total Load Chart.  
 \* When using two falls hook or single fall hook, use the appropriate four falls Rated Total Load Chart shown above but with a maximum load of: -1410kg for two falls and -710kg for Single fall.

## Working Range (4 falls)

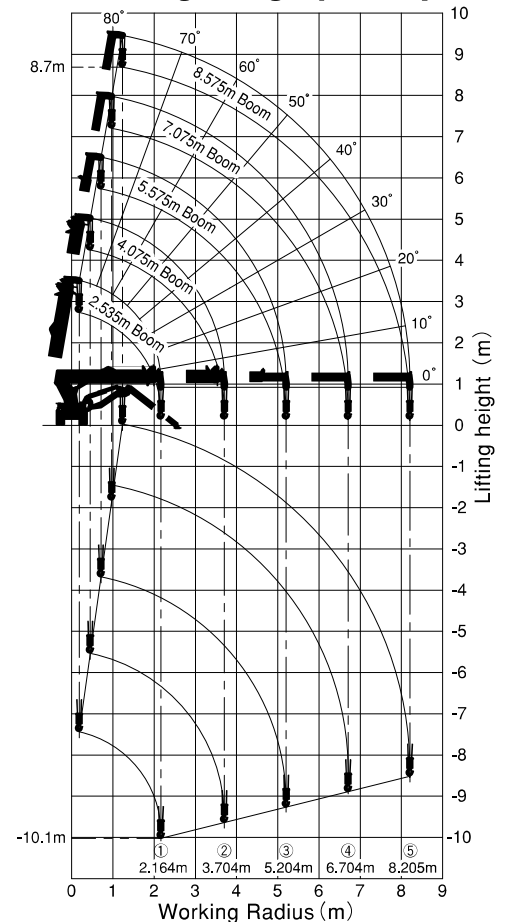

\* The Working Range Chart does not take into account boom deflection under load.



## MAEDA SEISAKUSHO CO.,LTD.

No.1095, Onbegawa, Shinonoi, Nagano-City, Nagano-Pref. 388-8522 Japan  
 Head office TEL. +81 (0)26 292 2228 FAX. +81 (0)26 293 8499  
 URL : <http://www.maesei.co.jp/> E-mail : [contact@maesei.co.jp](mailto:contact@maesei.co.jp)